

# TMC2272A

## Digital Colorspace Converter

### 36 Bit Color, 50 MHz

### Features

- 50 MHz (20ns) pipelined throughput
- 3 Simultaneous 12-bit input and output channels (64 Giga { $2^{36}$ } colors)
- Two's complement inputs and outputs
- Overflow headroom available in lower resolution
- 10-bit user-defined coefficients
- TTL compatible input and output signals
- Full precision internal calculation
- Output rounding
- On-board coefficient memory
- Submicron CMOS process

### Applications

- Translation between component color standards (RGB, YIQ, YUV, etc.)
- Broadcast composite color encoding and decoding (all standards)
- Broadcast composite color standards conversion and transcoding
- Camera tube and monitor phosphor colorimetry correction
- White balancing and color-temperature conversion
- Image capture, processing and storage
- Color matching between systems, cameras and monitors
- Three-dimensional perspective translation

### Description

A 50-MHz, three-channel, 36 bit (three 12-bit components) colorspace converter and color corrector, the TMC2272A uses 9 parallel multipliers to process high-resolution imagery in real time.

The TMC2272A also operates at any slower clock rate and with any smaller data path width, allowing it to handle all broadcast and consumer camera, frame-grabber, encoder/decoder, recorder and monitor applications as well as most electronic imaging applications.

A complete set of three 12-bit samples is processed on every clock cycle, with a five-cycle pipeline latency. Full 23-bit (for each of three components) internal precision is provided

with 10-bit user-defined coefficients. The coefficients may be varied dynamically, with three new coefficients loaded every clock cycle. (The full set of nine can be replaced in three clock cycles.) Rounding to 12 bits per component is performed only at the final output. This allows full accuracy with correct rounding and overflow headroom for applications that require less than 12 bits per component.

The TMC2272A is fabricated in a submicron CMOS process and performance is guaranteed over the full operating temperature range. It is available in a 120-pin Plastic Pin-Grid Array (PPGA) package and 120-pin Plastic Quad FlatPack (PQFP) in three speed grades.

### Logic Symbol

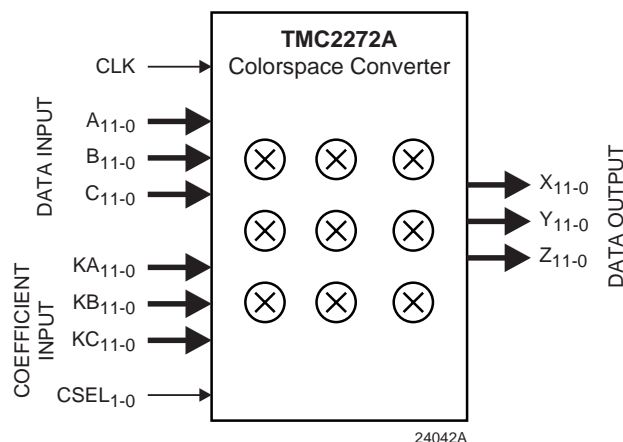

# Block Diagram

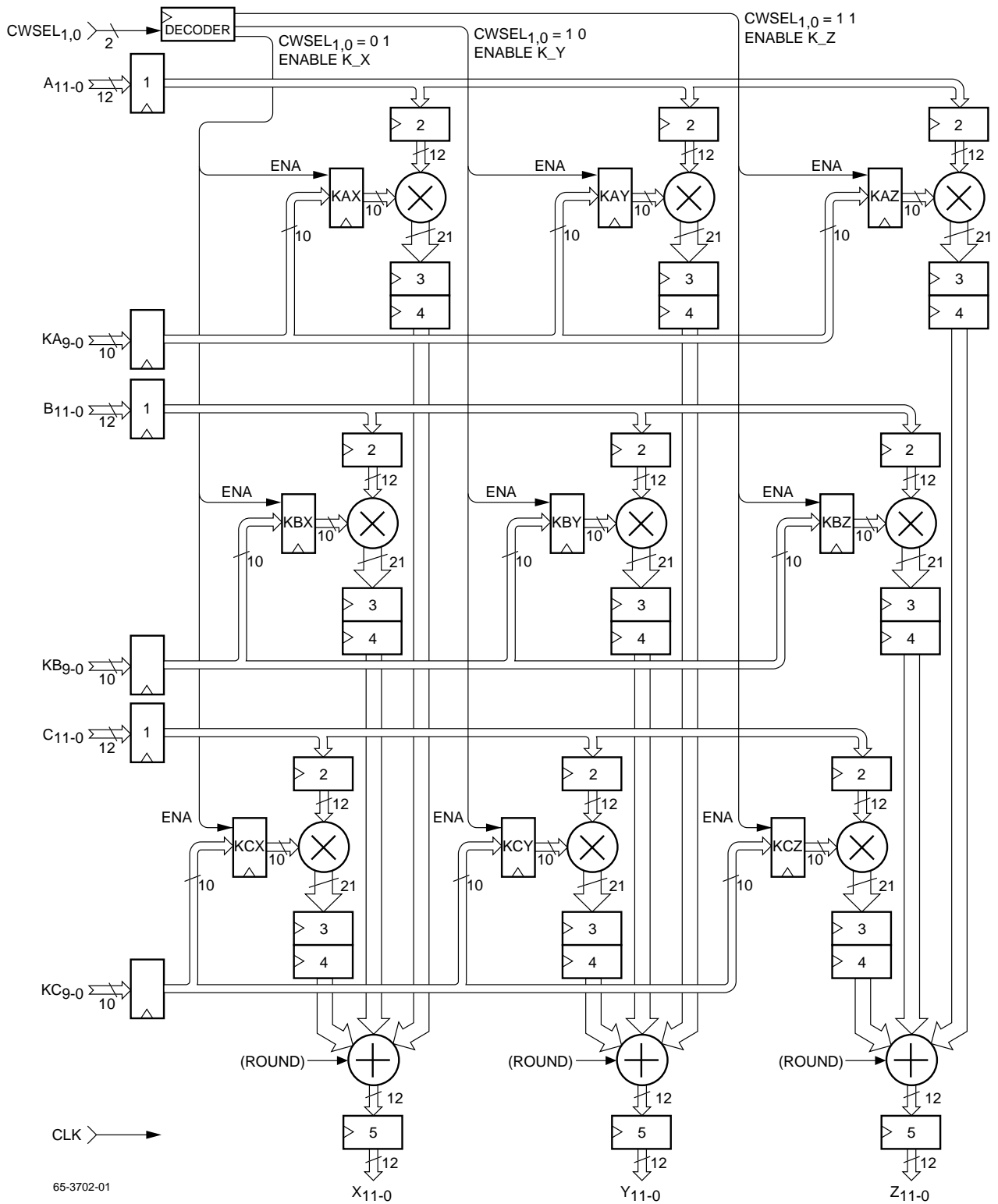

## Functional Description

The TMC2272A is a nine-multiplier array with the internal bus structure and summing adders needed to implement a 3 x 3 matrix multiplier (triple dot product). With a 50MHz guaranteed maximum clock rate, this device offers video and imaging system designers a single-chip solution to numerous common image and signal-processing problems.

The three data input ports (A<sub>11-0</sub>, B<sub>11-0</sub>, C<sub>11-0</sub>) accept 12-bit two's complement integer data, which is also the format for the output ports (X<sub>11-0</sub>, Y<sub>11-0</sub>, Z<sub>11-0</sub>). Other format and path width options are discussed in the numeric format and overflow section. The coefficient input ports (KA, KB, KC) are always 10-bit two's complement fractional. Table 2 details the bit weighting.

Full precision is maintained throughout the TMC2272A. Each output is accurately rounded to 12 bits from the 23 bits entering the final adder.

### Signal Definitions

A(n), B(n), C(n)

Indicates the data word presented to that input port during the specified clock rising edge (n). Applies to input ports A<sub>11-0</sub>, B<sub>11-0</sub>, and C<sub>11-0</sub>.

KAX(n) thru KCZ(n)

Indicates coefficient value stored in the specified one of the nine onboard coefficient registers KAX through KCZ, input during or before the specified clock rising edge (n).

X(n), Y(n), Z(n)

Indicates data available at that output port t<sub>DO</sub> after the specified clock rising edge (n). Applies to output ports X<sub>11-0</sub>, Y<sub>11-0</sub>, and Z<sub>11-0</sub>.

The TMC2272A utilizes six input and output ports to realize a "triple dot product", in which each output is the sum of all three input words, multiplied by the appropriate stored coefficients. The three corresponding sums of products are available at the outputs five clock cycles after the input data are latched, and three new data words rounded to 12-bits are then available every clock cycle. See the Applications Discussion regarding encoded video standard conversion matrices.

$$X(5)=A(1)KAX(1)+B(1)KBX(1)+C(1)KCX(1)$$

$$Y(5)=A(1)KAY(1)+B(1)KBY(1)+C(1)KCY(1)$$

$$Z(5)=A(1)KAZ(1)+B(1)KBZ(1)+C(1)KCZ(1)$$

## Pin Assignments

### 120 Pin Plastic Grid Array, H5 Package

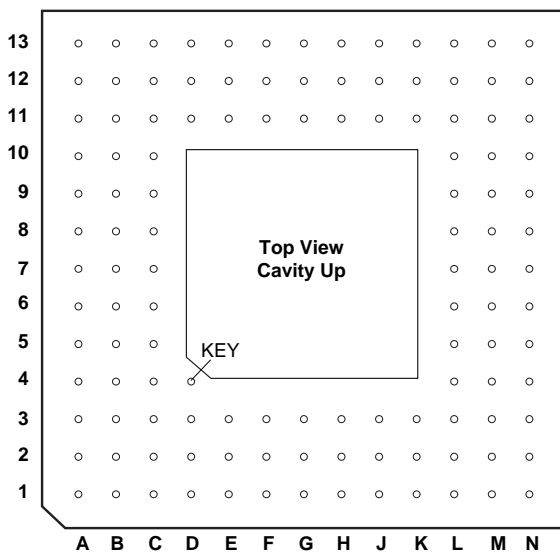

65-3702-02

Pin	Name	Pin	Name	Pin	Name	Pin	Name
A1	X7	C5	GND	G11	A3	L10	KB8
A2	X9	C6	C10	G12	A2	L11	KA1
A3	X10	C7	GND	G13	A4	L12	KA5
A4	GND	C8	VDD	H1	Y4	L13	KA6
A5	C11	C9	C0	H2	Y0	M1	Z2
A6	C8	C10	B8	H3	VDD	M2	Z7
A7	C7	C11	B5	H11	GND	M3	Z9
A8	C5	C12	B3	H12	A0	M4	Z11
A9	C3	C13	B1	H13	A1	M5	KC2
A10	C1	D1	Y11	J1	Y1	M6	KC4
A11	B10	D2	X0	J2	Y2	M7	KC6
A12	B7	D3	X3	J3	GND	M8	KC9
A13	B4	D11	CLK	J11	KA8	M9	KB2
B1	X4	D12	B0	J12	CWSEL1	M10	KB5
B2	X5	D13	A10	J13	CWSEL0	M11	KB9
B3	X8	E1	Y9	K1	Y3	M12	KA2
B4	X11	E2	Y10	K2	Z0	M13	KA3
B5	GND	E3	GND	K3	Z3	N1	Z5
B6	C9	E11	A11	K11	KA4	N2	Z8
B7	C6	E12	A9	K12	KA7	N3	Z10
B8	C4	E13	A8	K13	KA9	N4	KC1
B9	C2	F1	Y7	L1	Z1	N5	KC3
B10	B11	F2	Y8	L2	Z4	N6	KC5
B11	B9	F3	VDD	L3	Z6	N7	KC7
B12	B6	F11	A7	L4	GND	N8	KC8
B13	B2	F12	A6	L5	KC0	N9	KB1
C1	X1	F13	A5	L6	GND	N10	KB3
C2	X2	G1	Y5	L7	VDD	N11	KB6
C3	X6	G2	Y6	L8	KB0	N12	KB7
C4	VDD	G3	GND	L9	KB4	N13	KA0

## Pin Assignments (continued)

### 120 Pin Metric Quad Flat Pack (MQFP), KE Package

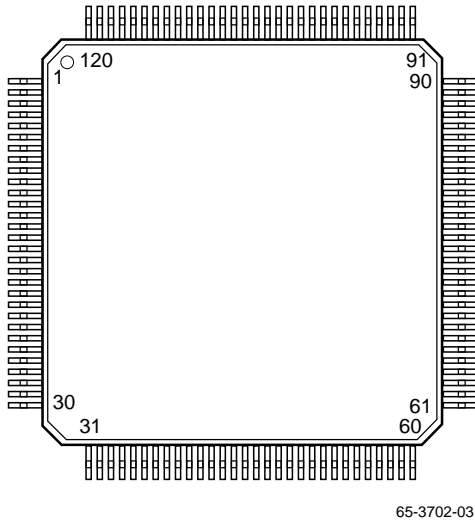

Pin	Name	Pin	Name	Pin	Name	Pin	Name
1	X6	31	Z6	61	KA1	91	B5
2	X5	32	Z7	62	KA2	92	B6
3	X4	33	Z8	63	KA3	93	B7
4	X3	34	GND	64	KA4	94	B8
5	X2	35	Z9	65	KA5	95	B9
6	X1	36	Z10	66	KA6	96	B10
7	X0	37	Z11	67	KA7	97	B11
8	GND	38	KC0	68	KA8	98	C0
9	Y11	39	KC1	69	KA9	99	C1
10	Y10	40	KC2	70	CWSEL1	100	C2
11	Y9	41	KC3	71	CWSEL0	101	C3
12	VDD	42	GND	72	GND	102	VDD
13	Y8	43	KC4	73	A0	103	C4
14	Y7	44	KC5	74	A1	104	C5
15	Y6	45	KC6	75	A2	105	C6
16	GND	46	VDD	76	A3	106	GND
17	Y5	47	KC7	77	A4	107	C7
18	Y4	48	KC8	78	A5	108	C8
19	Y0	49	KC9	79	A6	109	C9
20	VDD	50	KB0	80	A7	110	C10
21	Y1	51	KB1	81	A8	111	C11
22	Y2	52	KB2	82	A9	112	GND
23	Y3	53	KB3	83	A10	113	GND
24	GND	54	KB4	84	A11	114	GND
25	Z0	55	KB5	85	B0	115	X11
26	Z1	56	KB6	86	B1	116	X10
27	Z2	57	KB7	87	B2	117	X9
28	Z3	58	KB8	88	CLK	118	VDD
29	Z4	59	KB9	89	B3	119	X8
30	Z5	60	KA0	90	B4	120	X7

## Pin Descriptions

Pin Name	H5 Pin Number	KE Pin Number	Pin Function Description
<b>Power</b>			
V <sub>DD</sub>	F3, H3, L7, C8, C4	12, 20, 46, 102, 118	<b>Supply Voltage.</b> The TMC2272A operates from a single +5V supply. All pins must be connected.
GND	E3, G3, J3, L4, L6, H11, C7, C5, A4, B5	8, 16, 24, 34, 42, 72, 106, 112, 113, 114	<b>Ground</b>
<b>Clock</b>			
CLK	D11	88	<b>System Clock.</b> The TMC2272A operates from a single system clock input. All timing specifications are referenced to the rising edge of clock.
<b>Controls</b>			
CWSEL <sub>1,0</sub>	J12, J13	70, 71	<b>Coefficient Write Select.</b> This input selects which three of the 9 coefficient registers, if any, will be updated on the next clock cycle from the KA <sub>9-0</sub> , KB <sub>9-0</sub> , AND KC <sub>9-0</sub> inputs. See Table 4 and the Functional Block Diagram.

## Pin Descriptions (continued)

Pin Name	H5 Pin Number	KE Pin Number	Pin Function Description
<b>Inputs</b>			
A <sub>11-0</sub>	E11, D13, E12, E13, F11, F12, F13, G13, G11, G12, H13, H12	84, 83, 82, 81, 80, 79, 78, 77, 76, 75, 74, 73	<b>Data Input A.</b> This is one of three 12-bit wide data input ports.
B <sub>11-0</sub>	B10, A11, B11, C10, A12, B12, C11, A13, C12, B13, C13, D12	97, 96, 95, 94, 93, 92, 91, 90, 89, 87, 86, 85	<b>Data Input B.</b> This is one of three 12-bit wide data input ports.
C <sub>11-0</sub>	A5, C6, B6, A6, A7, B7, A8, B8, A9, B9, A10, C9	111, 110, 109, 108, 107, 105, 104, 103, 101, 100, 99, 98	<b>Data Input C.</b> This is one of three 12-bit wide data input ports.
KA <sub>9-0</sub>	K13, J11, K12, L13, L12, K11, M13, M12, L11, N13	69, 68, 67, 66, 65, 64, 63, 62, 61, 60	<b>Coefficient Input KAX, KAY, or KAZ.</b> These are the 10-bit wide coefficient input ports. The value at each of these three inputs will update one coefficient register as selected by the coefficient write select (CWSEL <sub>1-0</sub> ) on the next clock. See Table 1 and the Functional Block Diagram.
KB <sub>9-0</sub>	M11, L10, N12, N11, M10, L9, N10, M9, N9, L8	59, 58, 57, 56, 55, 54, 53, 52, 51, 50	<b>Coefficient Input KBX, KBY, OR KBZ.</b> These are the 10-bit wide coefficient input ports. The value at each of these three inputs will update one coefficient register as selected by the coefficient write select (CWSEL <sub>1-0</sub> ) on the next clock. See Table 1 and the Functional Block Diagram.
KC <sub>9-0</sub>	M8, N8, N7, M7, N6, M6, N5, M5, N4, L5	49, 48, 47, 45, 44, 43, 41, 40, 39, 38	<b>Coefficient Input KCX, KCY, OR KCZ.</b> These are the 10-bit wide coefficient input ports. The value at each of these three inputs will update one coefficient register as selected by the coefficient write select (CWSEL <sub>1-0</sub> ) on the next clock. See Table 1 and the Functional Block Diagram.
<b>Outputs</b>			
X <sub>11-0</sub>	B4, A3, A2, B3, A1, C3, B2, B1, D3, C2, C1, D2	115, 116, 117, 119, 120, 1, 2, 3, 4, 5, 6, 7	<b>Output X.</b> These are the data outputs. Data are available at the 12-bit registered Output Ports X,Y and Z t <sub>DO</sub> after every clock rising edge.
Y <sub>11-0</sub>	D1, E2, E1, F2, F1, G2, G1, H1, K1, J2, J1, H2	9, 10, 11, 13, 14, 15, 17, 18, 23, 22, 21, 19	<b>Output Y.</b> These are the data outputs. Data are available at the 12-bit registered Output Ports X,Y and Z t <sub>DO</sub> after every clock rising edge.
Z <sub>11-0</sub>	M4, N3, M3, N2, M2, L3, N1, L2, K3, M1, L1, K2	37, 36, 35, 33, 32, 31, 30, 29, 28, 27, 26, 25	<b>Output Z.</b> These are the data outputs. Data are available at the 12-bit registered Output Ports X,Y and Z t <sub>DO</sub> after every clock rising edge.

**Table 1. Coefficient Loading**

		CWSEL <sub>1,0</sub>			
		00	01	10	11
Input	KA <sub>9-0</sub>	Hold	Load	Load	Load
		All	KAX	KAY	KAZ
Input	KB <sub>9-0</sub>	Hold	Load	Load	Load
		All	KBX	KBY	KBZ
Input	KC <sub>9-0</sub>	Hold	Load	Load	Load
		All	KCX	KCY	KCZ

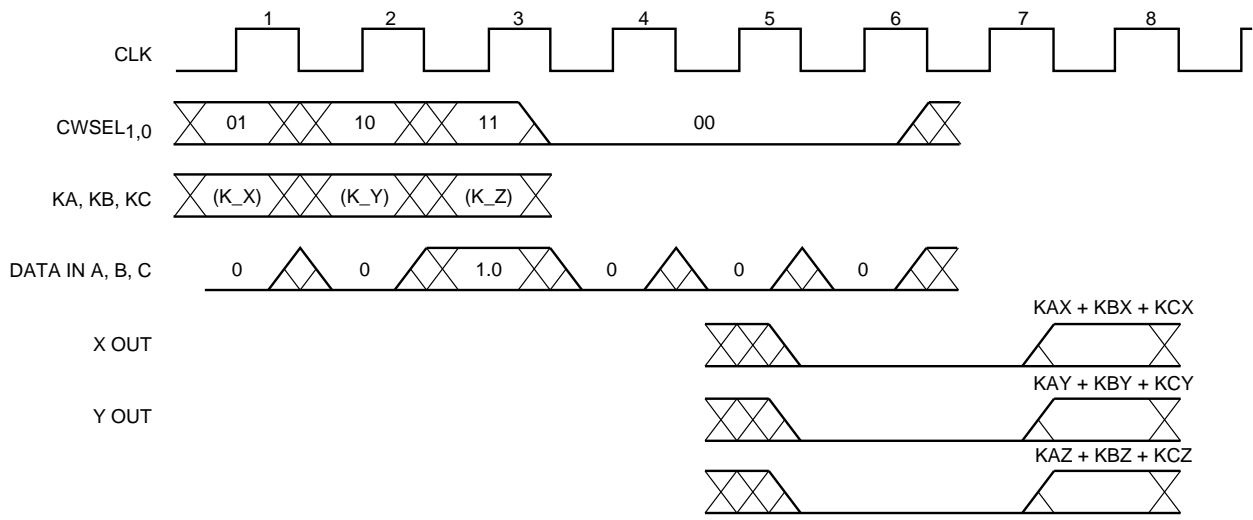

65-3702-04

Figure 1. Impulse Response

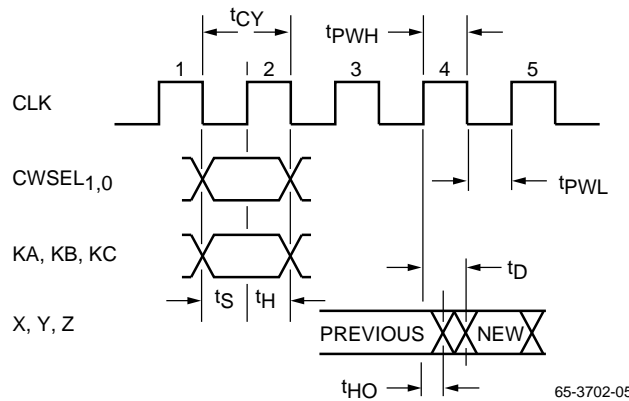

65-3702-05

Figure 2. Input/Output Timing

## Numeric Format and Overflow

Table 2 shows the binary weightings of the input and output ports of the TMC2272A. Although the internal sums of products could grow to 23 bits, the outputs X, Y, and Z are rounded to yield 12-bit integer words. Thus the output format is identical to the input data format. Bit weighting is easily adjusted by applying the same scaling correction factor to both input and output data words.

As shown in Table 2, the TMC2272A's matched input and output data formats accommodate 0dB (unity) gain. Therefore the user must be aware of input conditions that could lead to numeric overflow. Maximum input data and coefficient word sizes must be taken into account with the specific translation performed to ensure that no overflow occurs.

## Use with Fewer than 12 Bits

The TMC2272A can be configured to provide several format and overflow options when used in systems with fewer than 12 bits of resolution. An 8-bit system will be used as an example, however these concepts apply to any other word width.

The most apparent mode of operation is to left justify the incoming data and to ground the unused input LSBs. However, the outputs will still be rounded to the least significant bit of the TMC2272A, having little if any effect on the top 8 bits actually used. Because the TMC2272A carries out all calculations to full precision, the preferred mode of operation is to right justify and sign extend the data as shown in Figure 3. Since all the LSBs are used, the desired output will be rounded correctly, and overflow will be accommodated by bits 7 through 10.

The TMC2272A may also be used in unsigned binary 8-bit systems as shown in Figure 4. Bits 11 through 8 will handle overflow.

In all applications, a digital zero (ground) should be connected to all unused inputs.

**Table 2. Bit Weightings for Input and Output Data Words**

Bit Weights	$2^{11}$	$2^{10}$	$2^9$	$2^8$	$2^7$	$2^6$	$2^5$	$2^4$	$2^3$	$2^2$	$2^1$	$2^0$	.	$2^{-1}$	$2^{-2}$	$2^{-3}$	$2^{-4}$	$2^{-5}$	$2^{-6}$	$2^{-7}$	$2^{-8}$	$2^{-9}$	
<b>Inputs</b>																							
All Modes Data A, B, C	$-I_{11}$	$I_{10}$	$I_9$	$I_8$	$I_7$	$I_6$	$I_5$	$I_4$	$I_3$	$I_2$	$I_1$	$I_0$	.										
Coefficients KA, KB, KC													$-K_9$	$K_8$	$K_7$	$K_6$	$K_5$	$K_4$	$K_3$	$K_2$	$K_1$	$K_0$	
Internal Sum	$-X_{20}$	$X_{19}$	$X_{18}$	$X_{17}$	$X_{16}$	$X_{15}$	$X_{14}$	$X_{13}$	$X_{12}$	$X_{11}$	$X_{10}$	$X_9$	.	$X_8$	$X_7$	$X_6$	$X_5$	$X_4$	$X_3$	$X_2$	$X_1$	$X_0$	
<b>Outputs</b>																							
X, Y, Z	$-O_{11}$	$O_{10}$	$O_9$	$O_8$	$O_7$	$O_6$	$O_5$	$O_4$	$O_3$	$O_2$	$O_1$	$O_0$	.										

A minus sign indicates a two's complement sign bit.

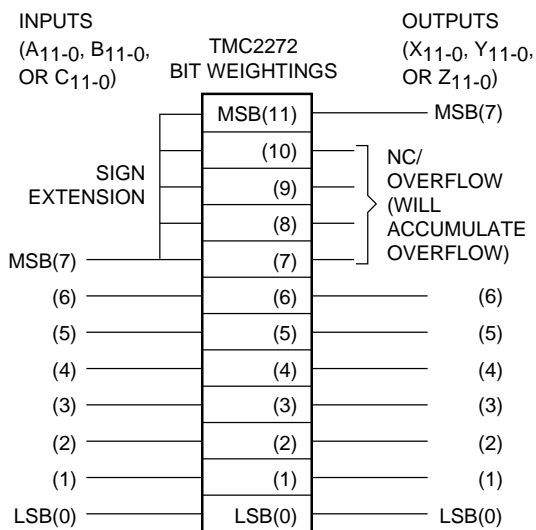

65-3702-06

**Figure 3. Two's Complement 8-bit Application**

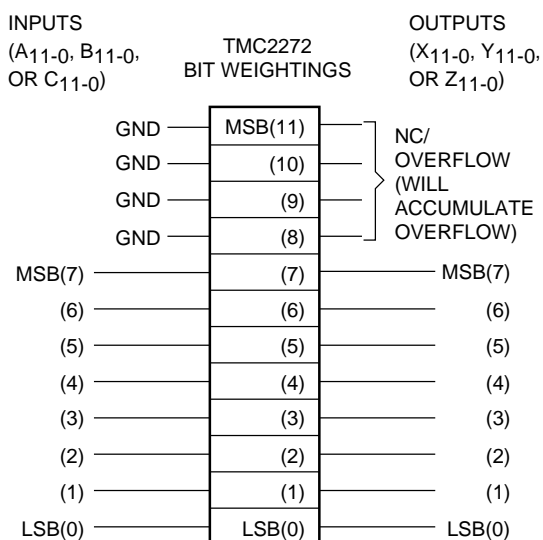

65-3702-07

**Figure 4. Binary 8-bit Application**

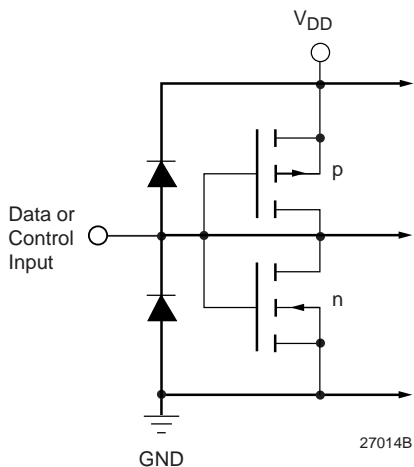

27014B

**Figure 5. Equivalent Digital Input Circuit**

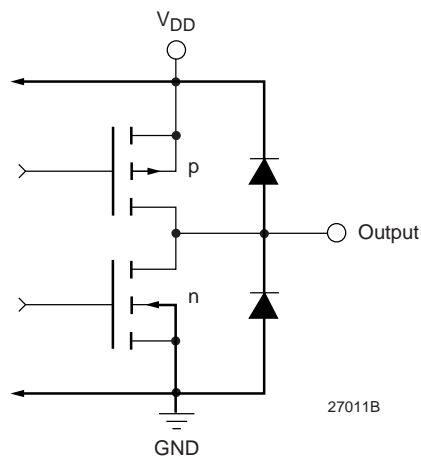

27011B

**Figure 6. Equivalent Digital Output Circuit**

## Absolute Maximum Ratings

(beyond which the device may be damaged)<sup>1</sup>

Parameter	Min	Typ	Max	Unit
Supply Voltage	-0.5		7.0	V
Input Voltage	-0.5		$V_{DD} + 0.5$	V
Applied Voltage <sup>2</sup>	-0.5		$V_{DD} + 0.5$	V
Externally Forced Current <sup>3,4</sup>	-3.0		6.0	mA
Short Circuit Duration (single output in HIGH state to ground)			1	sec
Operating, Ambient Temperature	-20		110	°C
Junction Temperature			140	°C
Storage Temperature	-65		150	°C
Lead Soldering Temperature (10 seconds)			300	°C

### Notes:

1. Absolute maximum ratings are limiting values applied individually while all other parameters are within specified operating conditions. Functional operation under any of these conditions is NOT implied. Performance and reliability are guaranteed only if Operating Conditions are not exceeded.
2. Applied voltage must be current limited to specified range.
3. Forcing voltage must be limited to specified range.
4. Current is specified as conventional current flowing into the device.

## Operating Conditions

Parameter		Min	Nom	Max	Units
$V_{DD}$	Power Supply Voltage	4.75	5.0	5.25	V
$f_{CLK}$	Clock Frequency	TMC2272A		30	MHz
		TMC2272A-2		40	MHz
		TMC2272A-3		50	MHz
$t_{PWH}$	CLK pulse width, HIGH	6			ns
$t_{PWL}$	CLK pulse width, LOW	8			ns
$t_S$	Input Data Setup Time	6			ns
$t_H$	Input Data Hold Time	2			ns
$V_{IH}$	Input Voltage, Logic HIGH	2.0			V
$V_{IL}$	Input Voltage, Logic LOW			0.8	V
$I_{OH}$	Output Current, Logic HIGH			-2.0	mA
$I_{OL}$	Output Current, Logic LOW			4.0	mA
$T_A$	Ambient Temperature, Still Air	0		70	°C



## Electrical Characteristics

Parameter		Conditions	Min	Typ	Max	Units
I <sub>DD</sub>	Total Power Supply Current	V <sub>DD</sub> = Max, C <sub>LOAD</sub> = 25pF, f <sub>CLK</sub> = Max				
		TMC2272A			125	mA
		TMC2272A-2			140	mA
		TMC2272A-3			155	mA
I <sub>DDU</sub>	Power Supply Current, Unloaded	V <sub>DD</sub> = Max, f <sub>CLK</sub> =Max				
		TMC2272A			120	mA
		TMC2272A-2			135	mA
		TMC2272A-3			150	mA
I <sub>DDQ</sub>	Power Supply Current, Quiescent	V <sub>DD</sub> = Max, CLK = LOW			12	mA
C <sub>PIN</sub>	I/O Pin Capacitance		5			pF
I <sub>IH</sub>	Input Current, HIGH <sup>1</sup>	V <sub>DD</sub> = Max, V <sub>IN</sub> = V <sub>DD</sub>			±5	μA
I <sub>IL</sub>	Input Current, LOW <sup>1</sup>	V <sub>DD</sub> = Max, V <sub>IN</sub> = 0 V			±5	μA
I <sub>OZH</sub>	Hi-Z Output Leakage Current, Output HIGH <sup>2</sup>	V <sub>DD</sub> = Max, V <sub>IN</sub> = V <sub>DD</sub>			±10	μA
I <sub>OZL</sub>	Hi-Z Output Leakage Current, Output LOW <sup>2</sup>	V <sub>DD</sub> = Max, V <sub>IN</sub> = 0 V			±10	μA
I <sub>OS</sub>	Short-Circuit Current		-20		-80	mA
V <sub>OH</sub>	Output Voltage, HIGH	I <sub>OH</sub> = Max, V <sub>DD</sub> = Min	2.4			V
V <sub>OL</sub>	Output Voltage, LOW	I <sub>OL</sub> = Max, V <sub>DD</sub> = Min			0.4	V

### Notes:

1. Except pins XC<sub>11-0</sub>, YC<sub>11-8</sub>.
2. Pins XC<sub>11-0</sub>, YC<sub>11-8</sub>.

## Switching Characteristics

Parameter		Conditions	Min	Typ	Max	Units
t <sub>DO</sub>	Output Delay Time	C <sub>LOAD</sub> = 25 pF			15	ns
t <sub>HO</sub>	Output Hold Time	C <sub>LOAD</sub> = 25 pF	3			ns

## Applications Discussion

The TMC2272A can convert between any two three-coordinate colorspaces with the selection of the proper coefficients. Sets of coefficients for some popular colorspace conversions are presented below.

By concatenating coefficient matrices of single transformations, the user can program the TMC2272A to perform compound transforms efficiently. For example, given an RGB input, correction of the relative values of R and B, for color temperature, conversion to YIQ, modification of contrast by

changing Y, and conversion back to RGB can be performed as quickly and easily as any simple transformation. To calculate the final set of coefficients from the coefficients of the individual transformations, the procedure in Figure 7 (concatenation) is used. If more than two matrices are to be combined, the result from the concatenation of the first two matrices is concatenated with the third. If more matrices must be incorporated in the final function, the last step is repeated.

$$\begin{vmatrix} A & B & C \\ D & E & F \\ G & H & I \end{vmatrix} \begin{vmatrix} J & K & L \\ M & N & O \\ P & Q & R \end{vmatrix} = \begin{vmatrix} AJ + BM + CP & AK + BN + CQ & AL + BO + CR \\ DJ + EM + FP & DK + EN + FQ & DL + EO + FR \\ GJ + HM + IP & GK + HN + IQ & GL + HO + IR \end{vmatrix}$$

65-3702-08

Figure 7. Concatenation

### Converting from GBR to YC<sub>B</sub>C<sub>R</sub>

With the right coefficients, two external NOT gates, and an external 4-bit half-adder, the TMC2272A can convert video data from 8-bit full-scale (e.g. VGA) GBR components to 10-bit YC<sub>B</sub>C<sub>R</sub> components.

Table 2. 10-bit component formats and inclusive ranges.

Color Space Term	Range	Format
Y Luminance	64-940	magnitude
Y' Y - 64	0-876	magnitude
C <sub>B</sub> Color difference, Blue	64-960	magnitude
U' C <sub>B</sub> - 512	±448	2's comp
C <sub>R</sub> Color difference, Red	64-960	magnitude
V' C <sub>R</sub> - 512	±448	2's comp
GBR Green, Blue, Red components	0-255	magnitude, 8-bits

The analog defining equations for 1 Volt luminance and ±0.5 Volt color difference components are:

$$Y = +0.5870(G) + 0.1140(B) + 0.2990(R)$$

$$B - Y = -0.3313(G) + 0.5000(B) - 0.1687(R)$$

$$R - Y = -0.4187(G) - 0.0813(B) + 0.5000(R)$$

To translate these equations into the digital domain, note that the ranges of R, G, and B are 0 to 255 instead of 0 to 1, the range of Y is 64 to 940 instead of 0 to 1, and the ranges of U and V are 64 to 960 instead of +/-0.5:

$$Y = (876/255)(0.587(G)+0.114(B)+0.299(R))+64 = 2.01652(G)+0.39162(B)+1.02715(R) + 64$$

$$C_B = (896/255)(0.3313(G)+0.5(B)-0.1687(R))+512 = -1.16397(G)+1.75686(B)-0.59289(R)+512$$

$$C_R = (896/255)(-0.4187(G)-0.0813(B)+0.5(R))+512 = -1.47115(G)-0.28571(B)+1.75686(B))+512$$

Let Y'=Y-64, U'=C<sub>B</sub>-512, and V'=C<sub>R</sub> - 512. The TMC2272A will compute Y', U', and V'. Adding 64 (040<sub>h</sub>) externally to Y' will then yield Y, whereas inverting the most significant bits of U' and V', U'9 and V'9, will yield C<sub>B</sub> and C<sub>R</sub>, respectively. Multiplying the equations immediately above by 128 and rounding each coefficient to the nearest integer yields the recommended set of coefficients for GBR to YUV conversion.

$$128(Y') = 258(G) +50(B) +131(R) \text{ dec.} \\ 102 \quad 032 \quad 083 \text{ hex}$$

$$128(U') = -149(G) +225(B) -76(R) \text{ dec} \\ 36B \quad 0E1 \quad 3B4 \text{ hex}$$

$$128(V') = -188(G) -37(B) +225(R) \text{ dec.} \\ 344 \quad 3DB \quad 0E1 \text{ hex}$$

If the TMC2272A input data alignment for 8-bit GBR is:

```
0 0 G7 G6 G5 G4 G3 G2 G1 G0 0 0
0 0 B7 B6 B5 B4 B3 B2 B1 B0 0 0
0 0 R7 R6 R5 R4 R3 R2 R1 R0 0 0
```

then the output data alignment for 10-bit Y'U'V' is:

```
0 0 Y9 Y8 Y7 Y6 Y5 Y4 Y3 Y2 Y1 Y0
U9 U9 U9 U8 U7 U6 U5 U4 U3 U2 U1 U0
V9 V9 V9 V8 V7 V6 V5 V4 V3 V2 V1 V0
```

where the tripled U9 and V9 sign bits denote two's complement sign extensions. The factors of 4 in the input data format and 128 in the equations are absorbed by the internal 9-bit (factor of 512) right-shifting of the emerging results.

At the output of the TMC2272A, invert the most significant bits, U9 and V9, of the chrominance components, and add 1 at Y6 of the luminance to obtain the true CCIR Rec. 601 values.

### Converting from GBR to 8-bit Full-Scale YUV

With the right coefficients and two external NOT gates, the TMC2272A can convert video data from 8-bit full-scale (e.g. VGA) GBR components to 8-bit full-scale YUV components.

**Table 3. 8-bit component formats and inclusive ranges:**

Color Space Term	Range	Format
Y Luminance	0-255	magnitude
U Color difference, Blue	128 to -127	2's comp
U' U + 128	0-255	magnitude
V Color difference, Red	128 to -127	2's comp
V' V + 128	0-255	magnitude
G,B,R Green, Blue, Red components	0-255	magnitude

As in the previous RGB to  $Y'U'V'$  case, begin with the defining equations, but without the range compensation factors of 255/876 and 255/896:

$$Y = 0.5870 (G) + 0.1140 (B) + 0.2990 (R)$$

$$U = -0.3313 (G) + 0.5000 (B) - 0.1687 (R)$$

$$V = -0.4187 (G) - 0.0813 (B) + 0.5000 (R)$$

The TMC2272A will compute Y, U, and V directly, whereas inverting the most significant bits of U and V, U7 and V7 will yield U' and V', respectively. Multiplying the equations immediately above by 512 and rounding each coefficient to the nearest integer yields the recommended set of coefficients for GBR to YUV conversion.

$$512 (Y) = \begin{matrix} 301 & + 58 & + 153 \\ 12D & 03A & 099 \end{matrix} \begin{matrix} (G) \\ (B) \\ (R) \end{matrix} \begin{matrix} \text{dec.} \\ \text{hex} \end{matrix}$$

$$512 (U) = \begin{matrix} -170 & + 256 & - 86 \\ 356 & 100 & 3AA \end{matrix} \begin{matrix} (G) \\ (B) \\ (R) \end{matrix} \begin{matrix} \text{dec.} \\ \text{hex} \end{matrix}$$

$$512 (V) = \begin{matrix} -214 & - 42 & + 256 \\ 32A & 3D6 & 100 \end{matrix} \begin{matrix} (G) \\ (B) \\ (R) \end{matrix} \begin{matrix} \text{dec.} \\ \text{hex} \end{matrix}$$

If the TMC2272A input data alignment for 8-bit GBR is:

```
0 0 0 0 G7 G6 G5 G4 G3 G2 G1 G0
0 0 0 0 B7 B6 B5 B4 B3 B2 B1 B0
0 0 0 0 R7 R6 R5 R4 R3 R2 R1 R0
```

then the output data alignment for 8-bit YUV is:

```
0 0 0 0 Y7 Y6 Y5 Y4 Y3 Y2 Y1 Y0
U7 U7 U7 U7 U7 U6 U5 U4 U3 U2 U1 U0
V7 V7 V7 V7 V7 V6 V5 V4 V3 V2 V1 V0
```

where the quintupled U9 and V9 sign bits denote two's complement sign extensions. The factor of 512 in the equations above is absorbed by the internal 9-bit right shift of each emerging result.

At the output of the TMC2272A, invert the most significant bits, U7 and V7, of the chrominance components, to obtain the 8-bit offset format.

### Converting From $Y'U'V'$ to GBR

Following the notation employed earlier, the TMC2272A will be used to convert data in  $Y'U'V'$  format into GBR format.

Since  $Y' = 876$ ,  $U' = V' = 0$ , and  $G = B = R = 255$  for saturated white output, every  $Y'$  coefficient will be  $225/876 = 0.29110$ . The full analog matrix for  $Y'U'V'$  to GBR conversion is:

$$G = 0.29110 (Y') - 0.09794 (U') - 0.20324 (V')$$

$$B = 0.29110 (Y') + 0.50431 (U')$$

$$R = 0.29110 (Y') + 0.39901 (V')$$

Since the largest element is just over 0.5 and the largest permissible coefficient is 511, multiply all elements of the matrix by 512 to obtain the values to load into the TMC2272A.

$$G = \begin{matrix} 149 & - 50 & - 04 \\ 095 & 3CE & 398 \end{matrix} \begin{matrix} (Y') \\ (U') \\ (V') \end{matrix} \begin{matrix} \text{dec.} \\ \text{hex} \end{matrix}$$

$$B = \begin{matrix} 149 & + 258 \\ 095 & 100 \end{matrix} \begin{matrix} (Y') \\ (U') \end{matrix} \begin{matrix} \text{dec.} \\ \text{hex} \end{matrix}$$

$$R = \begin{matrix} 149 & + 204 \\ 095 & 0CC \end{matrix} \begin{matrix} (Y') \\ (V') \end{matrix} \begin{matrix} \text{dec.} \\ \text{hex} \end{matrix}$$

Decrease the incoming luminance at the input to the TMC2272A by 64 by adding 1's at positions Y9, Y8, Y7, and Y6. Invert U9 and V9 and their sign extensions, to accommodate CCIR Rec. 601 data. Instead of reducing Y by 64, an alternate is to reduce each of the G, B, and R outputs by  $(255) (64 / 876) = 19$ .

For the  $Y'U'V'$  to RGB conversion, the TMC2272A input data alignment for 10-bit  $Y'U'V'$  is:

```
0 0 Y9 Y8 Y7 Y6 Y5 Y4 Y3 Y2 Y1 Y0
U9 U9 U9 U8 U7 U6 U5 U4 U3 U2 U1 U0
V9 V9 V9 V8 V7 V6 V5 V4 V3 V2 V1 V0
```

where the tripled U9 and V9 sign bits denote two's complement sign extensions. The TMC2272A output data alignment for 8-bit GBR is then:

0 0 0 0 G7 G6 G5 G4 G3 G2 G1 G0  
 0 0 0 0 B7 B6 B5 B4 B3 B2 B1 B0  
 0 0 0 0 R7 R6 R5 R4 R3 R2 R1 R0

**Converting From 8-bit Full Scale YUV to GBR**

Following the notation employed earlier, the TMC2272A will be used to convert data in 8-bit YUV format into 8-bit GBR format.

Since  $Y = 256$ ,  $U = V = 0$ , and  $G = B = R = 255$  for saturated white output, every Y coefficient will be  $255 / 255 = 1.0$ . The full matrix for YUV to GBR conversion is:

$$G = 1.0 (Y) \quad -0.3443 (U) \quad -0.7142 (V)$$

$$B = 1.0 (Y) \quad +1.7727 (U)$$

$$R = 1.0 (Y) \quad +1.3965 (V)$$

Since the largest element is over 1.0 and the largest permissible coefficient is 511, multiply all elements of the matrix by 256 to obtain the values to load into the TMC2272A:

$$G = 256 (Y') \quad - 88 (U') \quad - 83 (V') \quad \begin{matrix} \text{dec.} \\ \text{hex} \end{matrix}$$

$$100 \quad 3A8 \quad 349$$

$$B = 256 (Y') \quad + 454 (U') \quad \begin{matrix} \text{dec.} \\ \text{hex} \end{matrix}$$

$$100 \quad 1C6$$

$$R = 256 (Y') \quad + 359 (V') \quad \begin{matrix} \text{dec.} \\ \text{hex} \end{matrix}$$

$$100 \quad 167$$

For the YUV to RGB conversion, the TMC2272A input data alignment for 10-bit Y'U'V' is:

0 Y9 Y8 Y7 Y6 Y5 Y4 Y3 Y2 Y1 Y0 0  
 U9 U8 U7 U6 U5 U4 U3 U2 U1 U0 0  
 V9 V8 V7 V6 V5 V4 V3 V2 V1 V0 0

where the doubled U9 and V9 sign bits denote two's complement sign extensions. The TMC2272A output data alignment for 8-bit GBR is then:

0 0 0 0 G7 G6 G5 G4 G3 G2 G1 G0  
 0 0 0 0 B7 B6 B5 B4 B3 B2 B1 B0  
 0 0 0 0 R7 R6 R5 R4 R3 R2 R1 R0

Note that the inputs have to be doubled because the coefficient gain is 256, whereas the internal gain is  $1 / 512$ , for a net gain of  $1/2$ .

**Table 4. Summary of Colorspace Conversion Coefficients**

Conversion	KAX	KAY	KAZ	KBX	KBY	KBZ	KCX	KCY	KCZ
RGB to YUV	099	3AA	100	12D	356	32A	03A	100	3D6
RGB to YC <sub>B</sub> C <sub>R</sub>	083	3B4	0E1	102	36B	344	032	0E1	3DB
YUV to RGB	100	100	100	000	3A8	1C6	167	349	000
YC <sub>B</sub> C <sub>R</sub> to RGB	149	149	149	000	3CE	102	0CC	398	000

**Table 5. Conversion Port Assignments and Alignments**

Port	AIN	BIN	CIN	XOUT	YOUT	ZOUT
RGB to YUV	R <sub>7-0</sub>	G <sub>7-0</sub>	B <sub>7-0</sub>	Y <sub>7-0</sub>	U <sub>7-0(e)</sub>	V <sub>7-0(e)</sub>
RGB to YC <sub>B</sub> C <sub>R</sub>	R <sub>7-0</sub>	G <sub>7-0</sub>	B <sub>7-0</sub>	Y <sub>9-0</sub>	U <sub>9-0(e)</sub>	V <sub>9-0(e)</sub>
YUV to RGB	Y <sub>8-1(e)</sub>	U <sub>8-1(e)</sub>	V <sub>8-1(e)</sub>	R <sub>7-0</sub>	G <sub>7-0</sub>	B <sub>7-0</sub>
YC <sub>B</sub> C <sub>R</sub> to RGB	Y <sub>9-0</sub>	C <sub>B9-0(e)</sub>	C <sub>R9-0(e)</sub>	R <sub>7-0</sub>	G <sub>7-0</sub>	B <sub>7-0</sub>

Where X<sub>Y-0</sub> denotes right-justified, (e) denotes sign extension, and X<sub>Y-1</sub> denotes shifted one bit leftward from a right-justified position.

### HSV (HSI) Format Conversions

HSV (or HSI) refers to Hue (color), Saturation (vividness), and Value (intensity or brightness), quantities which are directly related to the human perception of light and color. The V (or I) levels are simply the Y (or luminance) levels. Hue and Saturation are derived from the R-Y and B-Y color difference values of a signal.

HSV Calculations:

$$\text{Value (V)} = \text{Intensity (I)} = Y$$

$$\text{Hue (H)} = \text{Arctan} (B-Y/R-Y)$$

$$\text{Saturation (S)} = \sqrt{(R - Y)^2 + (B - Y)^2}$$

$$R-Y = S * \cos(H)$$

$$B-Y = S * \sin(H)$$

One may use two 64Kx8 ROM look-up-tables to calculate Hue and Saturation from R-Y and B-Y in an 8-bit system. However, the finite size of this LUT may limit performance, especially if the TMC2272A's full precision is used. The TMC2330A, developed to translate between rectangular and polar coordinates, can perform the trigonometric transformations to 16 bit precision at 50MHz. These calculations are the same as required in HSV calculations. A 4 Gigabyte x 32 bit LUT can achieve the same accuracy and precision as the TMC2330A, if it is programmed correctly.

To convert between Y, R-Y, B-Y and HSV, the TMC2272A isn't needed at all; simply use the TMC2330A. To convert between HSV and any other format, use the TMC2330A to translate between HSV and Y, R-Y, B-Y, and use the TMC2272A to translate between Y, R-Y, B-Y and the other format. See Figures 8 and 9.

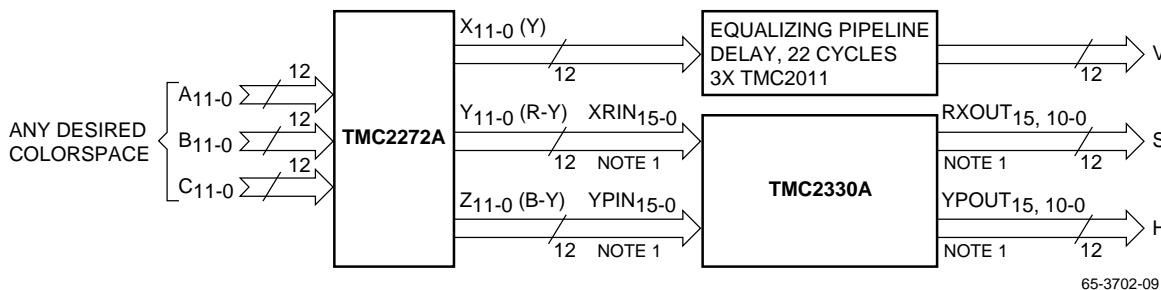

65-3702-09

**Notes:**

1. Connect TMC2272A MSBs (Bits 11) to TMC2330A MSBs (Bits 15) and also to TMC2330A Bits 14-11. Connect TMC2272A LSBs (Bits 10-0) to TMC2330A LSBs (Bits 10-0). TMC2330A output bits 14-11 are overflow.
2. TMC2272A Y<sub>11-0</sub> outputs should not be confused with the designation "Y" used to signify the intensity components. The assignment of components to TMC2272A inputs and outputs may be altered through the selection of appropriate coefficients.

**Figure 8. Conversion to HSV**

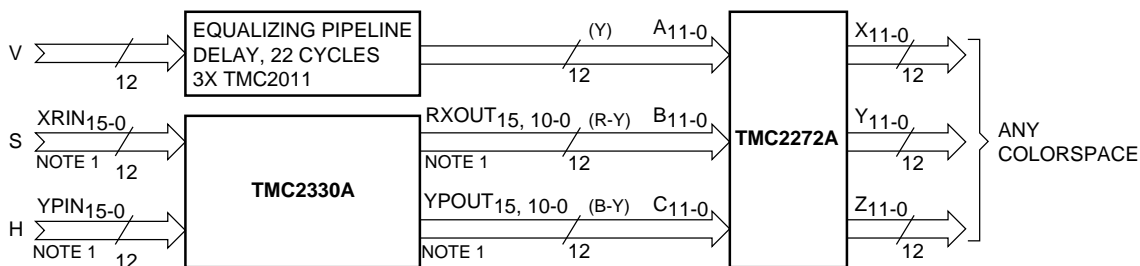

65-3702-10

**Notes:**

1. Connect input MSBs (Bits 11) to TMC2330A MSBs (Bits 15) and also to TMC2330A Bits 14-11. Connect input LSBs (Bits 10-0) to TMC2330A LSBs (Bits 10-0).
2. TMC2272A Y<sub>11-0</sub> outputs should not be confused with the designation "Y" used for an intensity component. Component assignment depends on the coefficient used.

**Figure 9. Conversion from HSV**

### Input Interpolation/Output Decimation and Filtering

In some applications the two color-difference signals (R-Y/B-Y or Cr/Cb, for example) are transmitted at one-half the rate of the luminance (Y) signal. These two color-difference signals are often multiplexed to one signal which is at the same sample rate as the luminance signal.

In many applications, if the color difference signals are already band-limited, it is satisfactory to use the same color difference sample for each two luminance samples. Little improvement is obtained with a simple averaging  $([A+B]/2)$  interpolation filter. If the color difference signal is not band-limited, either of these two methods may yield unsatisfactory results due to aliasing. In this case, a Raytheon TMC2242B

digital low-pass (half-band) interpolating filter will correctly band-limit each color difference signal as it is interpolated. See Figure 10.

The same methods are used to decimate the color difference outputs. Simple decimation by removing every other sample of color information may yield unsatisfactory results due to aliasing. This is a problem because the color difference signals have not been transformed with the higher-bandwidth luminance signals and therefore have higher bandwidths than they had before the transform. The best performance is obtained by using a precise low-pass (half-band) decimation filter such as the TMC2242B to remove aliasing components. See Figure 11.

The TMC2242B is a bi-directional, selectable rate filter/interpolator/decimator.

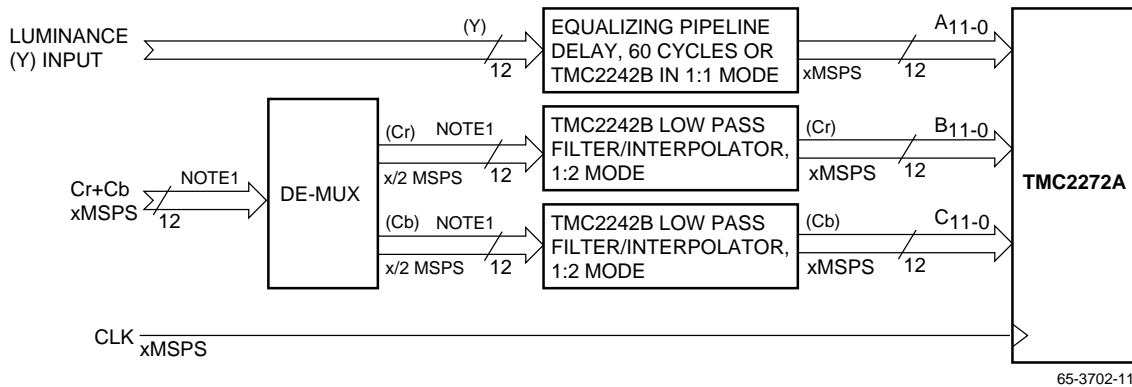

65-3702-11

**Notes:**

1. Width of input paths will vary with source.
2. See TMC2242B Datasheet for further information.

**Figure 10. Input Interpolation and Filtering**

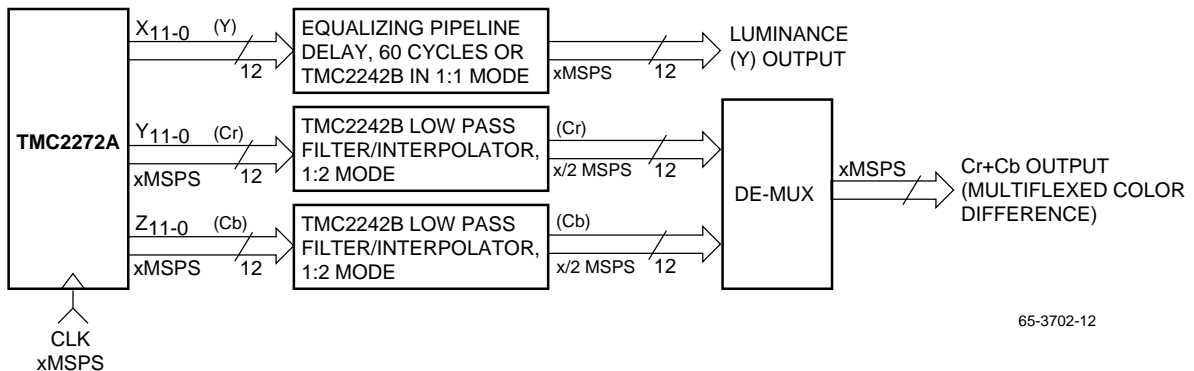

65-3702-12

**Figure 11. Output Decimation and Filtering**

## Related Products

- TMC1175 8 bit 40 Msps A/D Converter
- TMC2301 Image Resampling Sequencer
- TMC2302 Image Manipulation Sequencer
- TMC2249A Video Mixer
- TMC2242B Half-Band Filter
- TMC2330A Coordinate Transformer

**Notes:**



**Notes:**

# Mechanical Dimensions

## 121-Lead PPGA Package

Symbol	Inches		Millimeters		Notes
	Min.	Max.	Min.	Max.	
A	.080	.160	2.03	4.06	
A1	.040	.060	1.01	1.53	
A2	.125	.215	3.17	5.46	
øB	.016	.020	0.40	0.51	2
øB2	.050 NOM.		1.27 NOM.		2
D	1.340	1.380	33.27	35.05	SQ
D1	1.200 BSC		30.48 BSC		
e	.100 BSC		2.54 BSC		
L	.110	.145	2.79	3.68	
L1	.170	.190	4.31	4.83	
M	13		13		3
N	120		120		4
P	.003	—	.076	—	

**Notes:**

1. Pin #1 identifier shall be within shaded area shown.
2. Pin diameter excludes solder dip finish.
3. Dimension "M" defines matrix size.
4. Dimension "N" defines the maximum possible number of pins.
5. Orientation pin is at supplier's option.
6. Controlling dimension: inch.

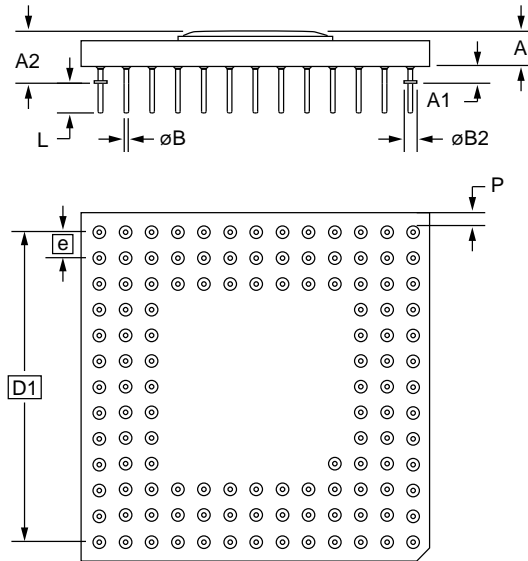
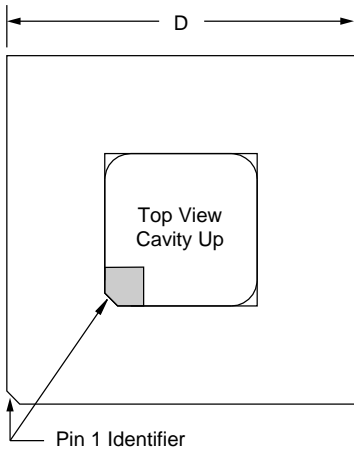

# Mechanical Dimensions (continued)

## 120-Lead MQFP Package

Symbol	Inches		Millimeters		Notes
	Min.	Max.	Min.	Max.	
A	—	.154	—	3.92	
A1	.010	—	.25	—	
A2	.125	.144	3.17	3.67	
B	.012	.018	.30	.45	3, 5
C	.005	.009	.13	.23	5
D/E	1.219	1.238	30.95	31.45	
D1/E1	1.098	1.106	27.90	28.10	
e	.0315 BSC		.80 BSC		
L	.026	.037	.65	.95	4
N	120		120		
ND	30		30		
$\alpha$	0°	7°	0°	7°	
ccc	—	.004	—	.10	

**Notes:**

1. All dimensions and tolerances conform to ANSI Y14.5M-1982.
2. Controlling dimension is millimeters.
3. Dimension "B" does not include dambar protrusion. Allowable dambar protrusion shall be .08mm (.003in.) maximum in excess of the "B" dimension. Dambar cannot be located on the lower radius or the foot.
4. "L" is the length of terminal for soldering to a substrate.
5. "B" & "C" includes lead finish thickness.

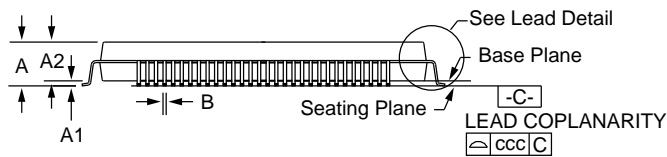
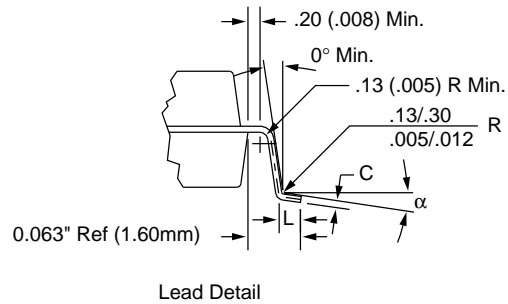
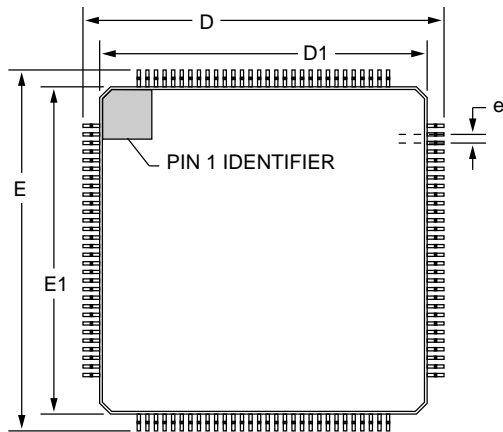

## Ordering Information

Product Number	Temperature Range	Speed Grade	Screening	Package	Package Marking
TMC2272AH5C	0°C to 70°C	30 MHz	Commercial	120 Pin Plastic Pin Grid Array	2272AH5C
TMC2272AH5C	0°C to 70°C	40 MHz	Commercial	120 Pin Plastic Pin Grid Array	2272AH5C2
TMC2272AH5C	0°C to 70°C	50 MHz	Commercial	120 Pin Plastic Pin Grid Array	2272AH5C3
TMC2272AKEC	0°C to 70°C	30 MHz	Commercial	120 Lead Plastic Quad Flatpack	2272AKEC
TMC2272AKEC	0°C to 70°C	40 MHz	Commercial	120 Lead Plastic Quad Flatpack	2272AKEC2
TMC2272AKEC	0°C to 70°C	50 MHz	Commercial	120 Lead Plastic Quad Flatpack	2272AKEC3

The information contained in this data sheet has been carefully compiled; however, it shall not by implication or otherwise become part of the terms and conditions of any subsequent sale. Raytheon's liability shall be determined solely by its standard terms and conditions of sale. No representation as to application or use or that the circuits are either licensed or free from patent infringement is intended or implied. Raytheon reserves the right to change the circuitry and any other data at any time without notice and assumes no liability for errors.

### LIFE SUPPORT POLICY:

Raytheon's products are not designed for use in life support applications, wherein a failure or malfunction of the component can reasonably be expected to result in personal injury. The user of Raytheon components in life support applications assumes all risk of such use and indemnifies Raytheon Company against all damages

Raytheon Electronics  
 Semiconductor Division  
 5580 Morehouse Drive  
 San Diego CA 92121  
 619 457 1000  
 FAX 619 455 6314  
[applications@lj.sd.ray.com](mailto:applications@lj.sd.ray.com)